

03-25 SERIES

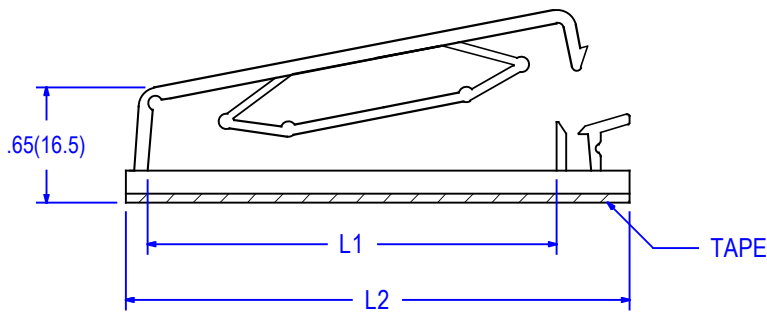
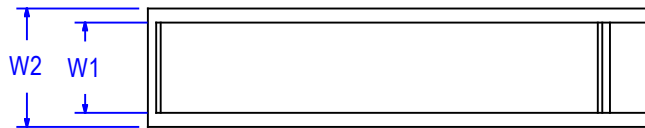
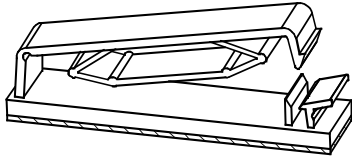

ITEM NO.	L1		L2		W1		W2		Cable Type
	In. ±.015	mm. ± 0.4	In. ±.015	mm. ± 0.4	In. ±.015	mm. ± 0.4	In. ±.015	mm. ± 0.4	
03-25-30	1.25	31.8	1.78	45.1	.630	16	.728	18.5	30 Pin
03-25-40	2.13	54	2.64	67	.465	11.8	.618	15.7	40 Pin
03-25-50	2.56	65	3.09	78.4	.622	15.8	.73	18.5	50 Pin

Packaging: 100 pcs per bag

ADHESIVE	ACRYLIC
CARRIER	POLYETHYLENE
THICKNESS	.043 (1.1) ±15%
COLOR	WHITE
UL FILE NO.	NA
RoHS COMPLIANCE	YES
SERVICE TEMPERATURE	158°F (70 °C)
MR NUMBER	48

MATERIAL	NYLON 66
UL RATING	94V-2
UL FILE NO.	E70062
COLOR	NATURAL
ASTM	D 4066, PA111
RoHS COMPLIANCE	YES
TEMPERATURE RANGE (REF.)	-40 to 185°F (-40 to 85°C)
MR NUMBER	13

					BY	DATE	Title CLAMP, FLAT CABLE Adhesive base.	
					CUSTOMER APPROVAL			
					VERIFIED			
					REVIEWED	FL	.	Part No. See Table
					DRAWN	FL	.12-16-16	Issue A
					DIMENSIONS Inches mm Tolerance xx = ± .010 xxx = .005			
.A	corrected column W2	1-17-17	FL	ALL ELECTRONICS HARDWARE INC. 2642 Corporate Parkway Algonquin, IL. 60102 1-800-778-7234			Drwg. type Catalog	01-17-17
No	Revision	Date	Init.				File No. 03-25 series	